

Precision Response (PR) and PR Plus Height Control Valves (HCVs)



Installation Instructions

General Information

Haldex Precision Response (PR & PR Plus) Height Control Valves (HCVs) automatically add and exhaust air from any air suspension to maintain a constant static design ride height. Haldex PR HCVs are perfect for light to heavy duty applications and can be installed on rear air, cab air and front air suspension applications.

The PR and PR Plus line offers an array of fittings, manifolds and integrated dump valve options and can be used in left- or right-hand installations with short or long control arms. Haldex PR HCVs feature an industry leading deadzone, can operate in hot and cold environments and decrease air consumption.

NOTE: Haldex PR & PR Plus HCV(s) can be interchanged with other brands of height control valves. Read instructions carefully for proper replacement and installation.

Pre-Installation Information

IMPORTANT: The HCV and linkage are designed to maintain the vehicle ride height as loads increase and decrease. Proper setup is critical to performance. Prior to any assembly or disassembly, please read all instructions. If you feel unable to properly install or adjust a Haldex PR or PR Plus, contact Haldex Technical Services or have a certified mechanic install or adjust the valve.

CAUTION: Incorrect installation of any HCV or associated component can impair suspension and vehicle performance. It is important that OEM specifications of a one or two HCV system be followed when installing an air control system. Refer to vehicle and suspension manufacturer's instructions for recommended valve location and ride height.

DO NOT install a single height control valve if the suspension or vehicle manufacturer specifies a dual HCV installation.

DO NOT use time delay valves on vehicles with a PR or PR Plus.

DO NOT use antifreeze or other solvents in an air supply line. Solvents or antifreeze can damage seals and void valve warranty.

NOTE: Conducting routine air system maintenance can help prevent damage to air system components. Never introduce foreign chemicals into any air system. Drain all moisture from air reservoirs at regular intervals.

ALWAYS use a Pressure Protection Valve (PPV) and filter such as the Haldex Part Number 90554107. Attach PPV directly to the air reservoir for supply to the PR & PR Plus HCV.

Figure 1.
Features of the PR Plus HCV

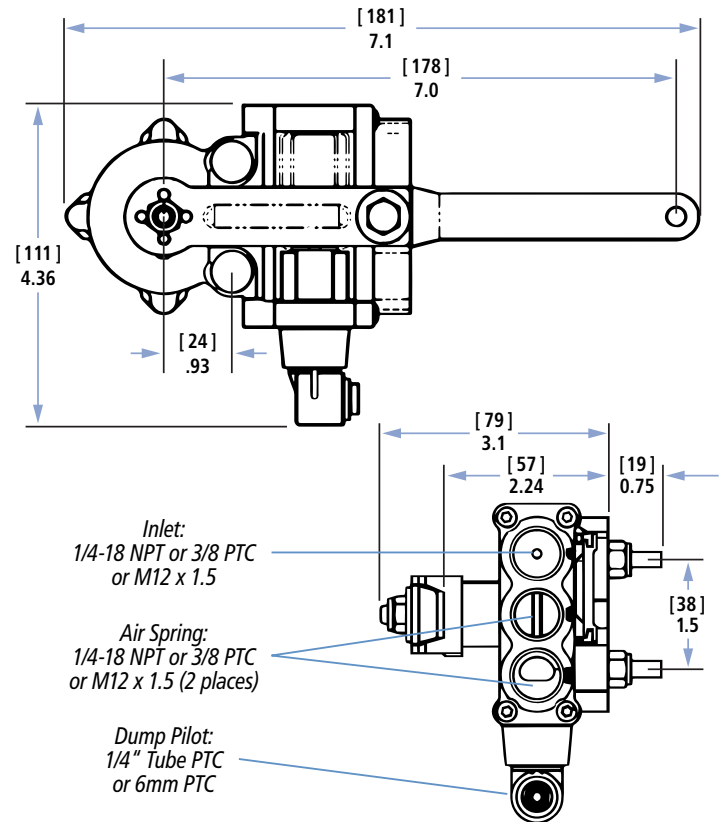
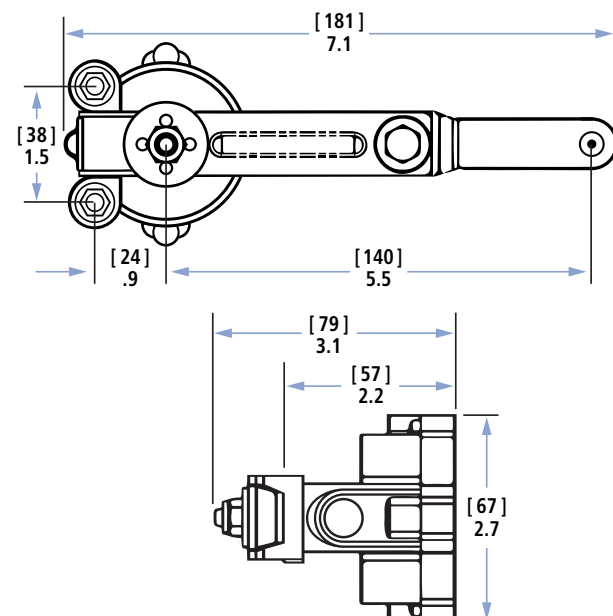

Figure 2.
Features of the PR HCV



Prepare Vehicle For Installation

NOTE: Prior to installation, rotate control arm 3-5 times 360 degrees in both the intake and exhaust directions to remove any adverse effects from storage.

1. Be sure that the suspension is centered between the frame rails before beginning installation. Vehicle should be unloaded before starting installation procedures. Be certain all dump switches are off. Park the vehicle making sure all vehicle wheels are on a hard, level surface. Raise and properly support all auxiliary axles. **DO NOT** set the parking brakes. Instead use safety wheel chocks to secure the vehicle.

WARNING: Failure to support auxiliary axles could allow axle to drop or the vehicle to roll resulting in death or serious personal injury.

Installing the PR and PR Plus HCV

2. Determine the desired control arm position and valve orientation on the vehicle.

Fasten the control arm to the interface cap and shaft making sure the alignment identifier dimple on the interface cap is in the proper position for your valve orientation. Refer to Fig. 3 & 4 for proper alignment identifier orientation. Use the provided nylok nut and tighten to 25-30 in-lbs. **DO NOT** over torque this nylok nut; it could result in a damaged or broken shaft.

If adjustable control arm is used, assemble with provided hardware. Torque the adjustment bolt to 25-30 in-lbs.

NOTE: Apply permanent thread locking compound on threaded shaft before tightening down the nylok nut.

3. If necessary, install fittings in HCV before mounting to the vehicle. Haldex recommends fittings with pre-applied seal compound. If recommended fittings are not available, use a drop of oil or thread-locker. Use small amounts of sealant on threads only. **DO NOT** use Teflon tape or pipe sealing compound.
4. Mount the PR & PR Plus HCV on the frame rail or a bracket and torque mounting nuts to 35-45 in-lbs. Hexagonal head fasteners can be used to mount the PR HCV. Integrated fasteners are already installed in the PR Plus HCV. For proper mounting bolt spacing see Fig. 1 & 2. The PR & PR Plus valves should be mounted as level as possible. A small torpedo level or mason's line level can help in this positioning.
5. a) Connect the air line from the air springs to the delivery (DEL) port(s) on the valve.
b) Connect the air line from the air supply tank to the supply (SUP) port on the valve.
c) Charge the air supply system.

NOTE: Supply port for PR HCV is the port closest to the mounting holes on the valve.

Figure 3.

PR Control Arm Orientation

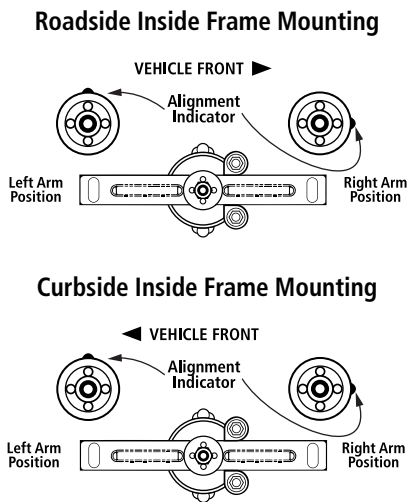
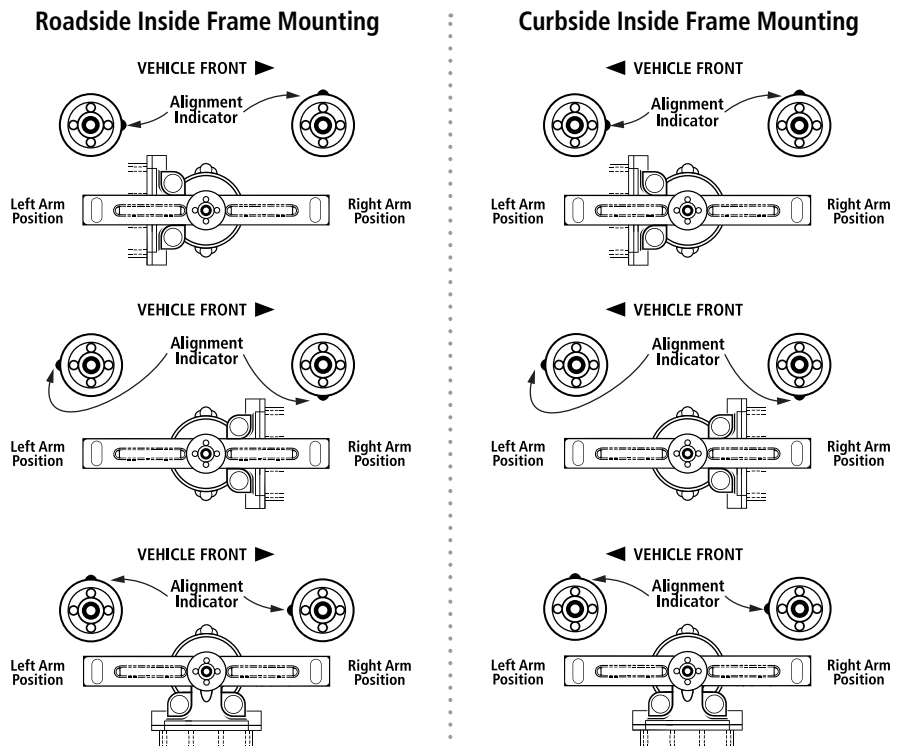

Figure 4.

PR Plus Control Arm Orientation



Verify System Operation

6. Confirm the control arm is properly installed by raising the control arm approximately 20° above horizontal. Air pressure should inflate the air springs. If the air springs do not inflate:
 - a) Verify the air supply pressure is sufficient enough to open the pressure protection valve (usually greater than 85 psi).
 - b) Recheck the air lines for proper port connection.
 - c) Make sure that any suspension dump/exhausting feature is not activated.
 - d) Determine if the control arm and alignment identifier dimple on the interface cap are in the proper orientation. Refer to Fig. 3 & 4.

If air system still fails to inflate air springs contact Haldex Technical Services.

If the PR or PR Plus HCV properly inflates the air springs, rotate the control arm down approximately 20° below horizontal. During normal operation the air is exhausted from under the interface cap as shown in Fig. 6. Verify air is flowing from under the interface cap and the air springs are deflating.

Ride Height Adjustment Instructions

NOTE: The following procedures require the vehicle to be parked over an inspection pit or level surface and may require two people working simultaneously when using a two HCV system.

7. Bring the suspension to the vehicle manufacturer's recommended ride height. Ride height is measured from the bottom of the frame rail to the center of the axle. Refer to the vehicle or suspension manufacturers manual for proper ride height measurement.
8. With the suspension at ride height and the HCV control arm at center position, determine the location of the lower linkage tab. A typical PR HCV and linkage assembly are shown in Fig. 5. Note the recommended angles between the HCV and linkage connection before installing the bottom linkage tab.
9. Damage to the valve, linkage and other suspension components may result if the recommended angles are not followed. Measure the distance from the control arm linkage mounting hole to the axle tab bracket mounting hole (Dim. "A" - Fig. 5). This is the required linkage length.
10. Connect the linkage to the control arm and axle tab bracket. For correct linkage assembly consult the suspension service manual.

IMPORTANT: Adjustments to the suspension ride height requires system air pressure. Adequate system air pressure must be maintained throughout adjustment procedures.

Figure 5.

PR HCV and linkage assembly

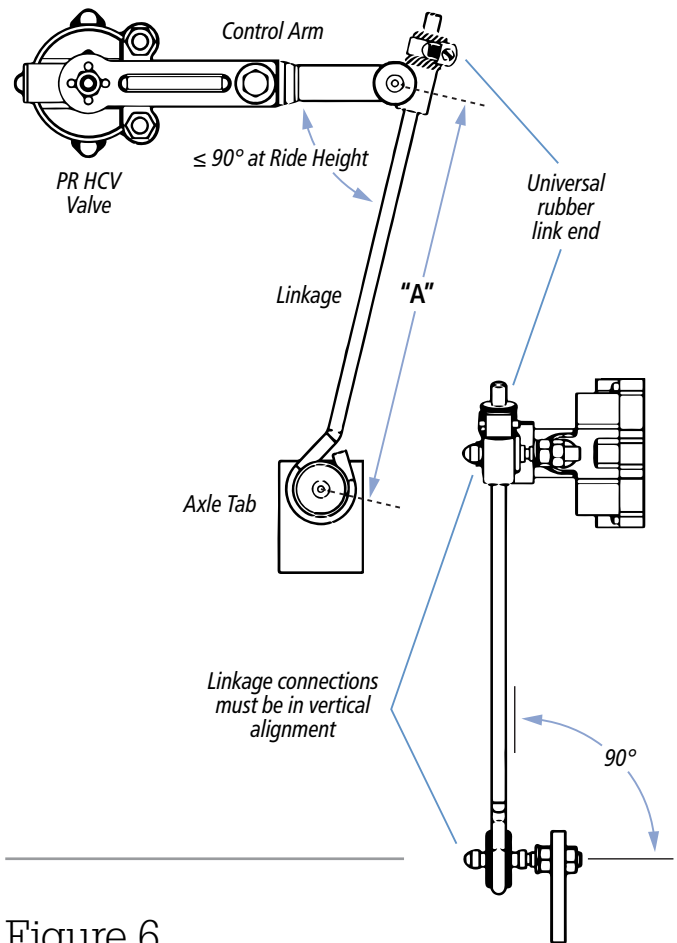
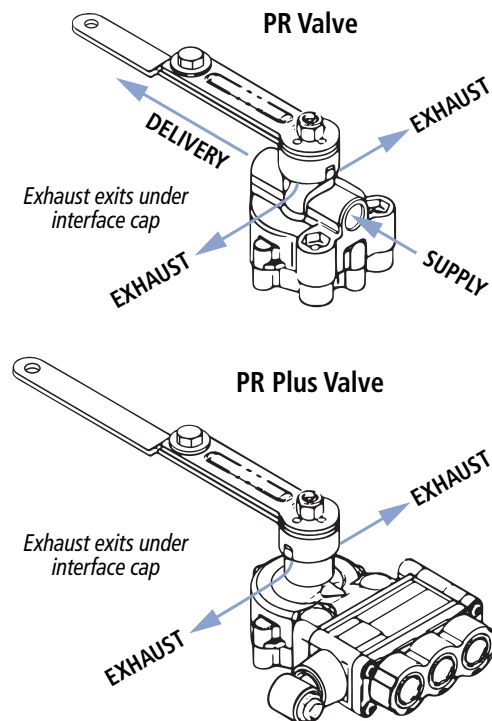

Figure 6.

Air Supply, Delivery and Exhaust



11. CHECK FOR PROPER RIDE HEIGHT. Disconnect the lower linkage end from the axle tab. Lower the control arm and linkage about 1" and hold for 15 seconds to lower the suspension. Reconnect the lower linkage end, the suspension should return to ride height. Measure the ride height on both sides of the vehicle to verify that the suspension is within the manufacturer's specified tolerance.

12. FINE ADJUST RIDE HEIGHT IF NECESSARY. Carefully adjust the linkage assembly or control arm to bring suspension to ride height. Your PR or PR Plus HCV may have an adjustable control arm which provides approximately 1" of ride height adjustment. After each adjustment of the linkage or control arm repeat previous step. This may require several attempts, repeat until proper ride height is obtained twice in a row.

NOTE: When using the adjustable control arm to make fine adjustments, torque bolt to 25-30 in-lbs.

FINAL CHECK. Soap spray test all air line connections for air leaks and verify that all fasteners are tight.

NOTE: Ride heights may vary slightly from the loaded to the unloaded condition.

NOTE: The vehicle should maintain air spring volume and remain near ride height during short periods out of service. An air suspension system can deflate during longer out of service periods.

NOTE: A small amount of air may escape from the exhaust located under the interface cap; this is normal and should not cause alarm or require replacement of the valve.

NOTE: If two valves are used on a chassis, then the valves must be located in the same position and location on each side of the vehicle. Proper installation of a 2 HCV system is required to ensure the air suspension system operates correctly.

Check for Linkage Interference

NOTE: The following procedures require the vehicle to be parked over an inspection pit or level surface and may require two people working simultaneously when using a two HCV system.

13. CHECK LINKAGE(S) FOR CLEARANCE. Disconnect the lower linkage connection and move the HCV control arm down to fully exhaust the suspension. Reconnect the lower linkage to verify linkage does not interfere with frame rail, electrical wiring or air lines. If there is linkage or control arm interference, change the valve or linkage axle tab position.

14. CHECK LINKAGE OPERATION WITH SUSPENSION AT FULL EXTENSION. Disconnect lower linkage from axle tab and move the HCV control arm up to raise suspension to full extension.

IMPORTANT: DO NOT continue to inflate air springs after full extension is reached. Damage to shock absorbers and/or air springs could result.

Figure 7.
Single Valve System

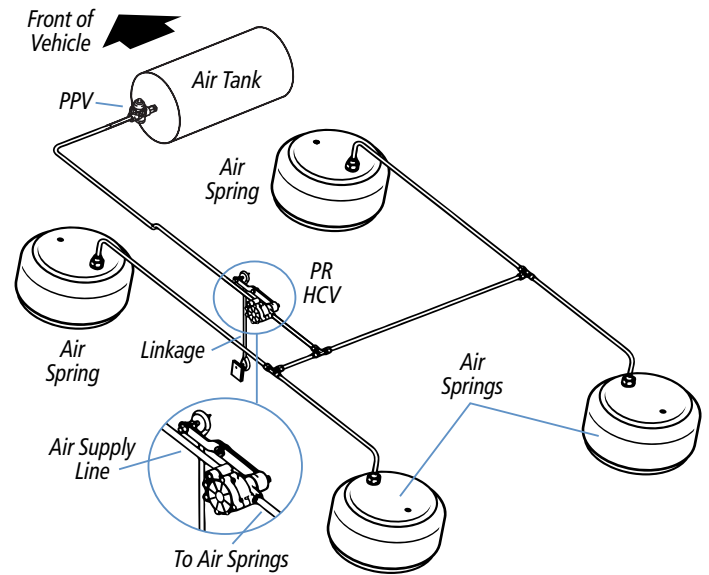
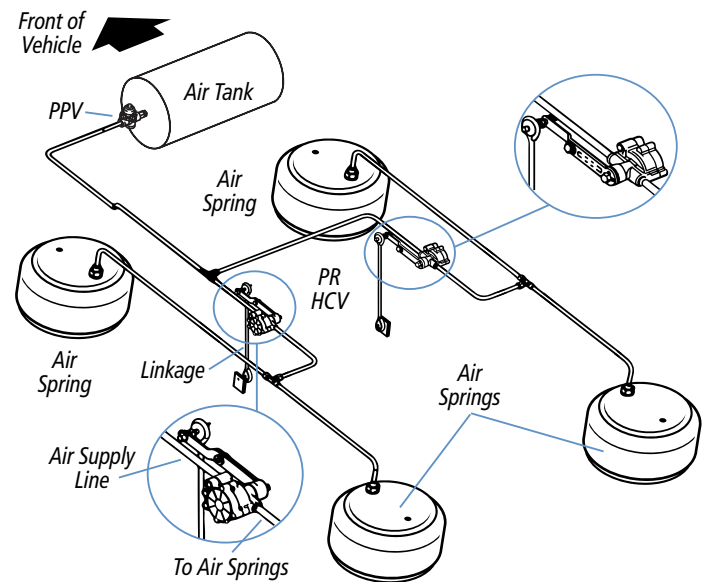

Figure 8.
Dual Valve System



Immediately reconnect lower linkage to axle tab. Verify the control arm/linkage connection rotates smoothly and is free of tension. If the linkage is in tension or the rubber link end is being pulled along the rod at full extension, the valve position and/or linkage axle tab will need to be moved.

Lowering/Exhausting Your Air Suspension

Certain applications may require that a vehicle's air suspension has the ability to fully lower or exhaust the air springs from ride height. The PR Plus HCV has the option of an integrated Normally Open or Normally Closed dump valve. The Normally Open dump valve is typically operated in conjunction with a manual switch or electric solenoid valve as shown in Fig. 9. The Normally Open dump valve allows air to be exhausted from the air springs when a pilot pressure is applied.

The Normally Closed valve is typically operated from the gladhand or emergency brake line as shown in Fig. 10. The Normally Closed dump valve allows air to be exhausted from the air springs when the pilot pressure is removed. It should be noted that the optional dump valve for the PR Plus HCV is NOT sold separately and CANNOT be replaced in the field.

The Haldex Pilot Valve, part number 90554615, can be used in conjunction with the PR HCV to provide air suspension exhausting. The Haldex Pilot Valve provides the capability to exhaust air from any air suspension in a Normally Open or Normally Closed operation.

Figure 9.

Normally open valve with manual switch or solenoid valve

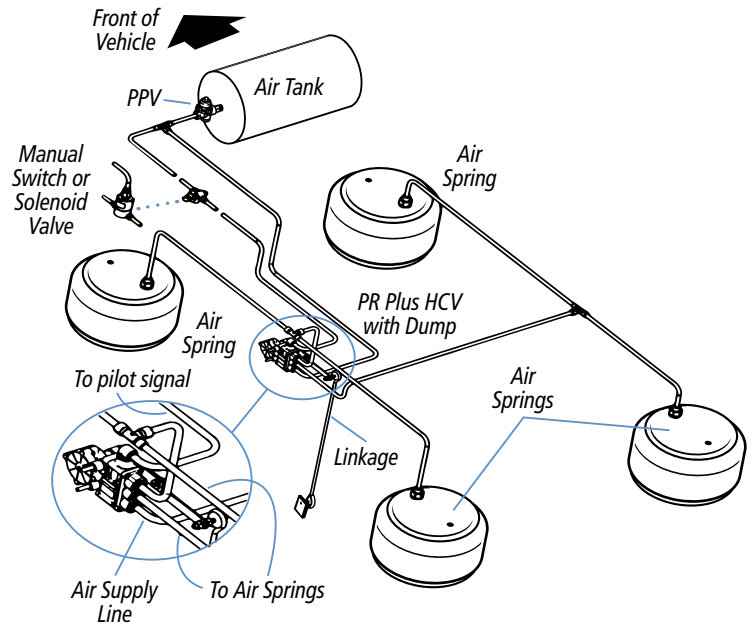
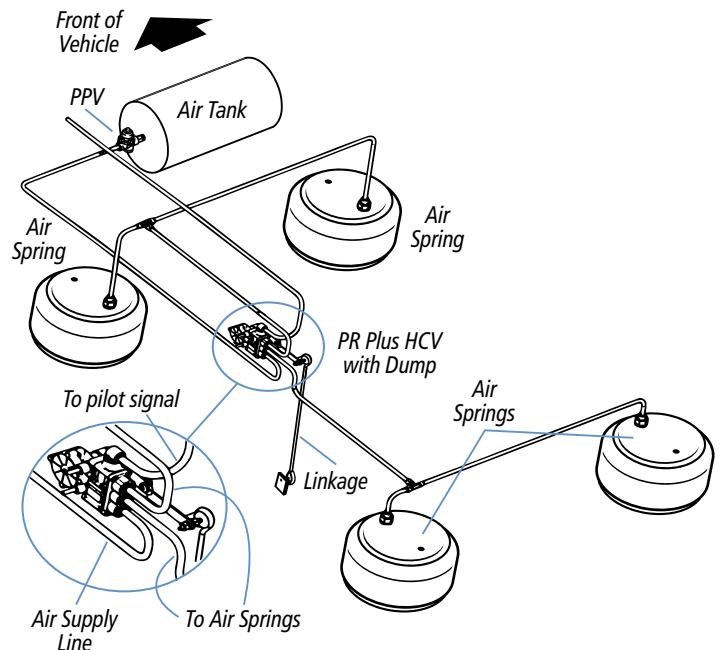

Figure 10.

Normally closed valve usually operates from the quick connector or emergency brake line



Additional parts available from Haldex enable you to:

Adjust linkages.

Part No.	Description
48100374	Looped Linkage Max. Length 16"
48100375	Looped Linkage Max. Length 22"
48100367	Strap Linkage Max. Length 14"

Add a suspension dump feature to your truck or trailer.

Part No.	Description
90554615	For Remote Mounted "Auto" or Manual Dump Installations

Upgrade Pressure Protection Valve to include inline filter.

Part No.	Description
90554107	PPV With Inline Filter